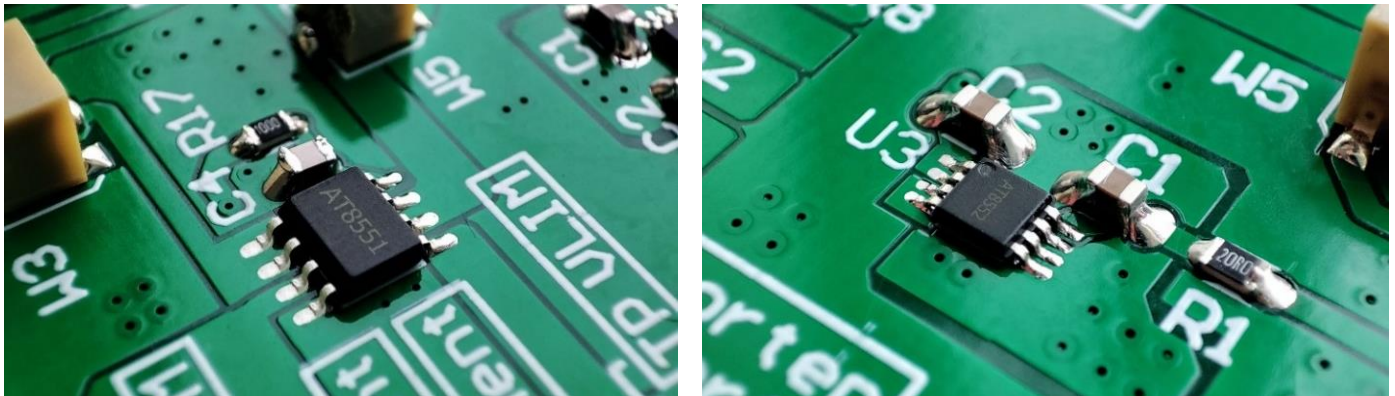

Figure 1. Physical Photos of AT8551



ORDERING GUIDE

Online Stores		Commission Fee	Unit Price (June 2024)	Buy Now
	shop.analogtechnologies Our own online store	Zero sale commission	\$0.90/100PCs	*
	SMTZone Our own online store	Zero sale commission	\$0.90/100PCs	*
	Digikey	≈32% sale commission	\$1.19/100PCs	*



Table 1. AT8551/8552 vs. AD8551/8552

Parameter	AT8551	AD8551
Offset Voltage	<5μV	10μV
Noise (0.01Hz to 10Hz)	<0.75μV _{P-P}	1μV _{P-P}
Slew Rate	2.7V/μs	0.4μV/μs
Bandwidth	4.5MHz	1.5MHz
Price	100~499pcs	\$0.90
	>1000pcs	\$0.78

FEATURES

- Upgraded Drop-in Replacement for AD8551
- Low Offset Voltage: 1μV (typ) 5μV (max)
- Input Offset Drift: 0.005μV/°C (max)
- High Gain Bandwidth Product: 4.5MHz
- Rail-to-Rail Input and Output
- High Gain, CMRR & PSRR: ≥130dB
- High Slew Rate: 2.7V/μs
- Low Noise: 0.75μV_{P-P} (0.01~10Hz)
- Low Power Consumption: 640μA/op amp
- Overload Recovery Time: 1μs
- Low Supply Voltage: +2.7V to +5.5V
- No External Capacitors Required
- Extended Temperature: -40°C to +125°C

APPLICATIONS

- Temperature & Pressure Sensors Amplifier

- Weight Scale & Strain Gage Amplifiers
- Medical/Industrial Instrumentation
- Handheld Test Equipment
- Precision Current Sensing
- Thermocouple Amplifiers

DESCRIPTION

This AT855x family includes single (AT8551) and dual (AT8552) general purpose CMOS operational amplifiers that provides ultralow noise, offset and power. The AT8551 use auto-zero techniques to simultaneously provide very low offset voltage (5μV max) and near zero-drift over time and temperature.

This miniature, high precision operational amplifiers offset high input impedance and rail-to-rail input and rail-to-rail output swing. With high gain bandwidth product of 4.5MHz and slew rate of 2.7V/μs.

This op amp operates as low as +2.7V (±1.35) and up to +5.5V (±2.75V). The AT8551 single amplifier is available in 5-lead SOT23, 8-lead MSOP8 and 8-lead SOIC packages, The AT8552 dual amplifier is available in 8-lead SOIC and 8-lead MSOP8 narrow surface mount packages. The AT8551/AT8552 (dual version) are specified for the extended industrial and automotive temperature range (-40°C to 125°C).

PIN CONFIGURATIONS

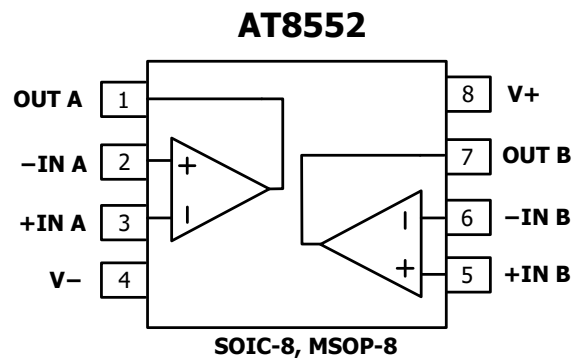
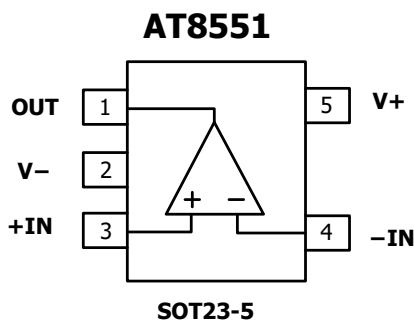



PIN DESCRIPTION

Descriptions of the pins are listed in Table 2 (single op amps) and Table 3 (dual op amps).

Table 2: Pin Function Table for Single OP AMPS

AT8551	Symbol	Description
SOT23-5		
1	OUT	Analog Output
2	V-	Negative Power Supply
3	+IN	Noninverting Input
4	-IN	Inverting Input
5	V+	Positive Power Supply
-	NC	No Internal Connection

Table 3: Pin Function Table for Dual OP AMPS

AT8552		Symbol	Description
MSOP-8	SOIC-8		
1	1	OUT A	Analog Output (Op Amp A)
2	2	-IN A	Inverting Input (Op Amp A)
3	3	+IN A	Noninverting Input (Op Amp A)
4	4	V-	Negative Power Supply
5	5	+IN B	Noninverting Input (Op Amp B)
6	6	-IN B	Inverting Input (Op Amp B)
7	7	OUT B	Analog Output (Op Amp B)
8	8	V+	Positive Power Supply

ABSOLUTE MAXIMUM RATINGS

Table 4.

Parameter	Rating
Supply Voltage, V+ to V-	7.0V
Input Terminals, Voltage (2)	-0.5 to (V+) + 0.5V
Input Terminals, Current (2)	±10mA
Storage Temperature	-65°C to +150°C
Operating Temperature	-40°C to +125°C
Junction Temperature	150°C
Package Thermal Resistance @ T _A = +25°C	



SOT23-5	200°C/W
MSOP-8, SOIC-8	150°C
Lead Temperature (Soldering, 10s)	260°C
ESD Susceptibility	
HBM	5000V
MM	400V

(1) Stresses beyond those listed under Absolute Maximum Ratings may cause permanent damage to the device. These are stress ratings only, and functional operation of the device at these or any other conditions beyond those indicated under Recommended Operating Conditions is not implied. Exposure to absolute-maximum-rated conditions for extended periods may affect device reliability.

(2) Input terminals are diode-clamped to the power supply rails. Input signals that can swing more than 0.5V beyond the supply rails should be current-limited to 10mA or less.

ESD CAUTION 

ESD (electrostatic discharge) sensitive device.

Charged devices and circuit boards can discharge without detection. Although this product features patented or proprietary protection circuitry, damage may occur on devices subjected to high energy ESD. Therefore, proper ESD precautions should be taken to avoid performance degradation or loss of functionality.

THERMAL CHARACTERISTICS

Table 5.

Package Type	8-Lead MSOP	8-Lead SOIC	5-Lead SOT23	Unit
R _{θJA} Junction-to-ambient thermal resistance	180.3	140.1	220.8	°C/W
R _{θJC} (top) Junction-to-case (top) thermal resistance	48.1	89.8	97.5	°C/W
R _{θJB} Junction-to-board thermal resistance	100.9	80.6	61.7	°C/W
ψ _{JT} Junction-to-top characterization parameter	2.4	28.7	7.6	°C/W
ψ _{JB} Junction-to-board characterization parameter	99.3	80.1	61.1	°C/W



ELECTRICAL CHARACTERISTICS

Limits apply over the specified temperature range: $T_A = -40^{\circ}\text{C}$ to $+125^{\circ}\text{C}$.

(At $T_A = +25^{\circ}\text{C}$, $V_S = 5\text{V}$, $R_L = 10\text{k}\Omega$ connected to $V_S/2$, and $V_{\text{OUT}} = V_S/2$, unless otherwise noted.)

Table 6.

Parameter	Symbol	Test Conditions	Min.	Typ.	Max.	Unit
INPUT CHARACTERISTICS						
Offset Voltage	V_{OS}	$V_{\text{CM}} = V_S/2$ $T_A = -40^{\circ}\text{C}$ to $+125^{\circ}\text{C}$		1	5	μV
Input Bias Current	I_{B}	$V_{\text{CM}} = V_S/2$ $T_A = -40^{\circ}\text{C}$ to $+125^{\circ}\text{C}$		50		pA
Input Offset Current	I_{OS}	$T_A = -40^{\circ}\text{C}$ to $+125^{\circ}\text{C}$		10		pA
Input Voltage Range	V_{IN}		2.7		5.5	V
Common-Mode Voltage Range	V_{CM}		$(V-) - 0.1$		$(V+) + 0.1$	V
Common-Mode Rejection Ratio	CMRR	$(V-) - 0.1\text{V} < V_{\text{CM}} < (V+) + 0.1\text{V}$ $T_A = -40^{\circ}\text{C}$ to $+125^{\circ}\text{C}$	110	130		dB
Offset Voltage Drift	$\Delta V_{\text{OS}}/\Delta T$	$T_A = -40^{\circ}\text{C}$ to $+125^{\circ}\text{C}$		0.005	0.05	$\mu\text{V}/^{\circ}\text{C}$
Channel Separation, dc				0.1		$\mu\text{V}/\text{V}$
Open-Loop Gain	A_{OL}	$R_L = 10\text{k}\Omega$, $V_O = 0.3\text{V}$ to 4.7V $T_A = -40^{\circ}\text{C}$ to $+125^{\circ}\text{C}$		110	130	dB
INPUT CAPACITANCE						
Differential				1		pF
Common-Mode				5		pF
OUTPUT CHARACTERISTICS						
Output Voltage High	V_{OH}	$R_L = 100\text{k}\Omega$ to GND $T_A = -40^{\circ}\text{C}$ to $+125^{\circ}\text{C}$	4.99	4.998		V
		$R_L = 10\text{k}\Omega$ to GND $T_A = -40^{\circ}\text{C}$ to $+125^{\circ}\text{C}$	4.95	4.98		V



Parameter	Symbol	Test Conditions	Min.	Typ.	Max.	Unit
Output Voltage Low	V _{OL}	R _L = 100kΩ to V ₊ T _A = -40°C to +125°C		1	10	mV
		R _L = 10kΩ to V ₊ T _A = -40°C to +125°C		10	30	mV
Output Short-Circuit Limit Current	I _{SC}	T _A = -40°C to +125°C		50		mA
POWER SUPPLY						
Power Supply Rejection Ratio	PSRR	V _S = +2.7V to +5.5V, V _{CM} = 0 T _A = -40°C to +125°C	110	130		dB
Quiescent Current/Amplifier	I _Q	V _O = 0 T _A = -40°C to +125°C		640	870	μA
Supply Voltage Range	V _{IN}		2.7		5.5	V
DYNAMIC PERFORMANCE						
Slew Rate	SR	G=+1		2.7		V/μs
Gain Bandwidth Product	GBP			4.5		MHz
Overload Recovery Time				1		μs
NOISE PERFORMANCE						
Voltage Noise	e _n p-p	0.01Hz to 10Hz		0.75		μV p-p
	e _n p-p	0.01Hz to 1Hz		0.22		μV p-p
Voltage Noise Density	e _n	f = 1kHz		35		nV/√Hz
Current Noise Density	i _n	f = 10Hz		1.5		fA/√Hz



TYPICAL CHARACTERISTICS

At $T_A = +25^\circ\text{C}$, $V_S = 5\text{V}$, $R_{LOAD} = 10\text{k}\Omega$ connected to $V_S/2$, $V_{OUT} = V_S/2$, unless otherwise noted.

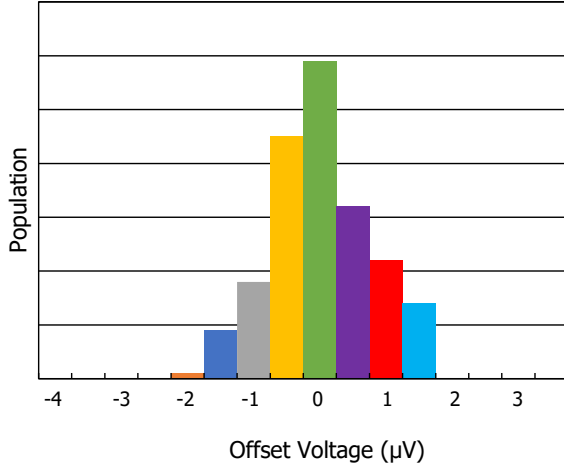

Offset Voltage Production Distribution

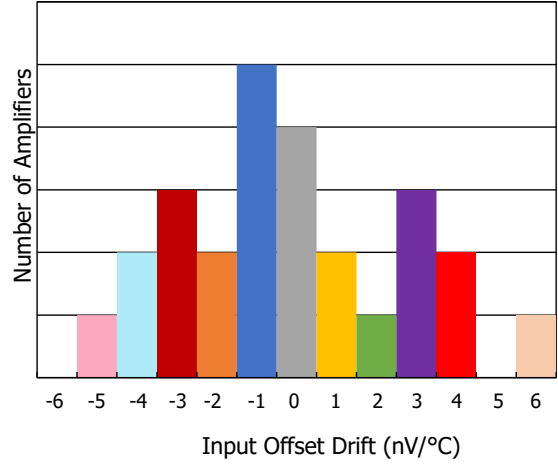

Offset Voltage Drift Production Distribution

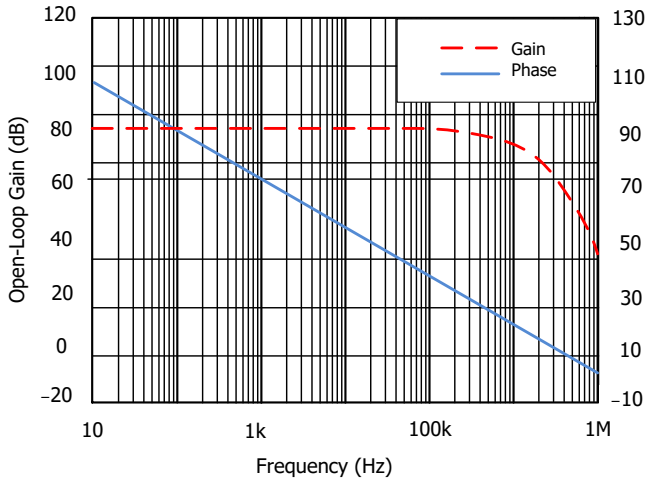

Open-Loop Gain and Phase vs. Frequency

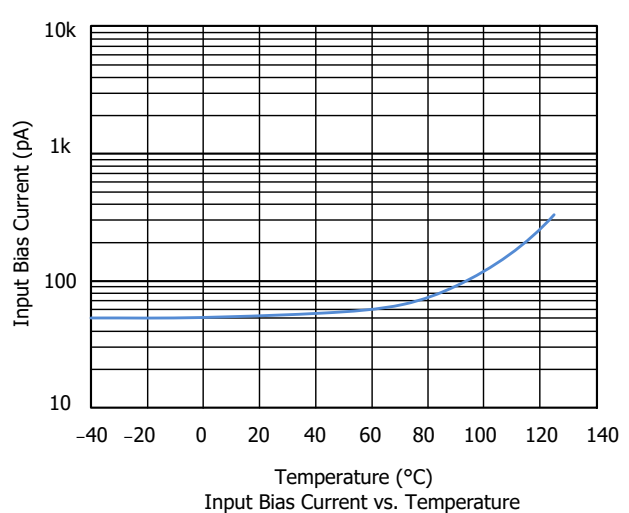

Input Bias Current vs. Temperature

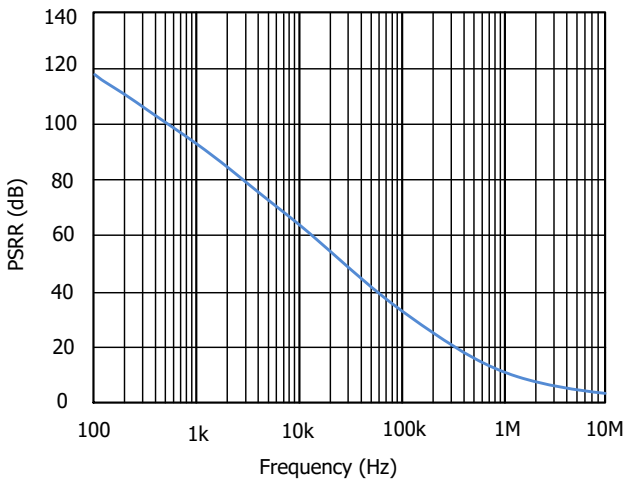

Power-Supply Rejection Ratio vs. Frequency

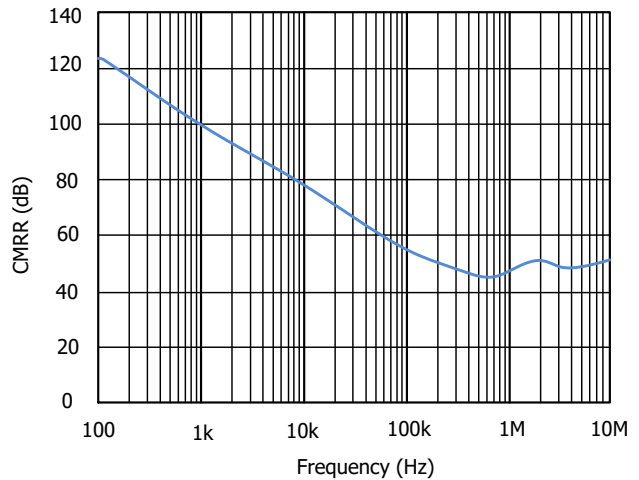

Input Bias Current vs. Temperature

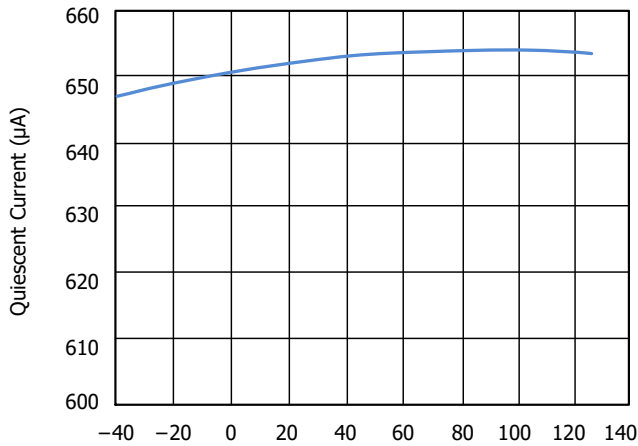

Temperature (°C) Vs=5V
Quiescent Current vs. Temperature

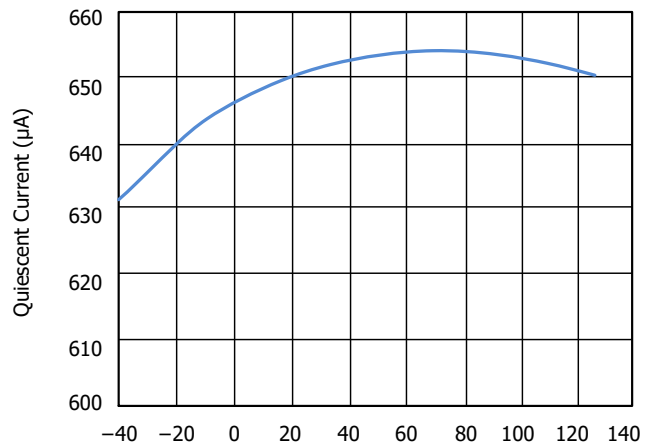

Temperature (°C) Vs=2.7V
Quiescent Current vs. Temperature

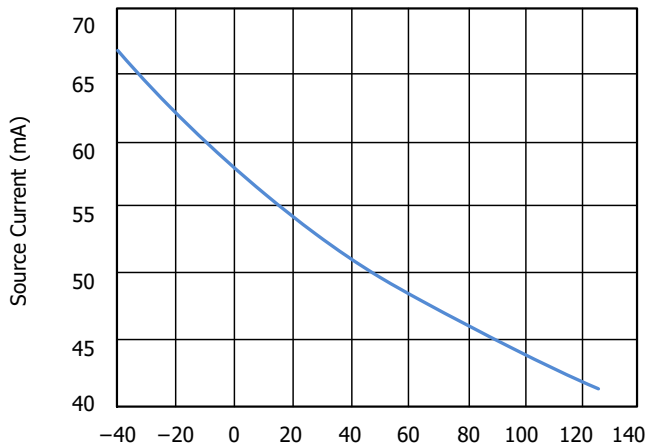

Temperature (°C)
Source Current vs. Temperature

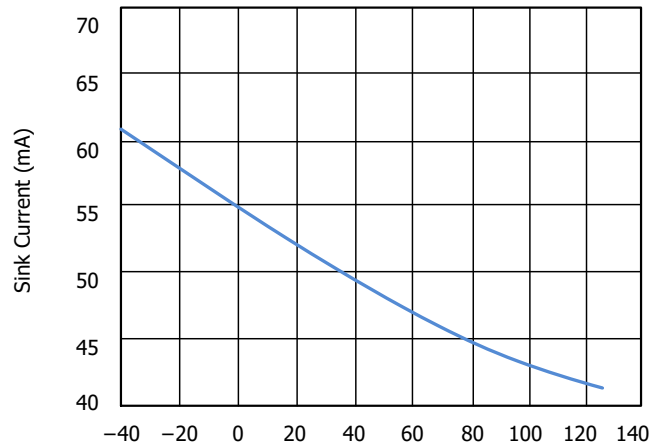

Temperature (°C)
Sink Current vs. Temperature

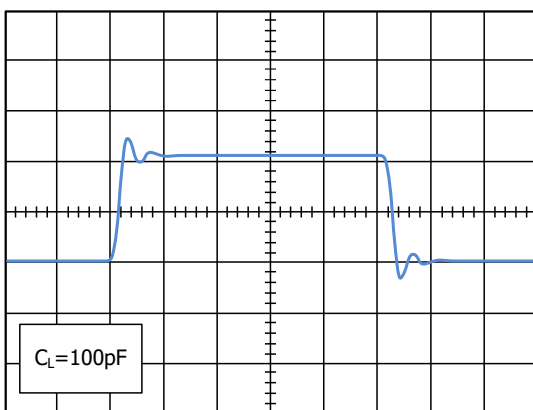

CH1: 50mV/Div M: 200ns/Div

Small-Signal Step Response

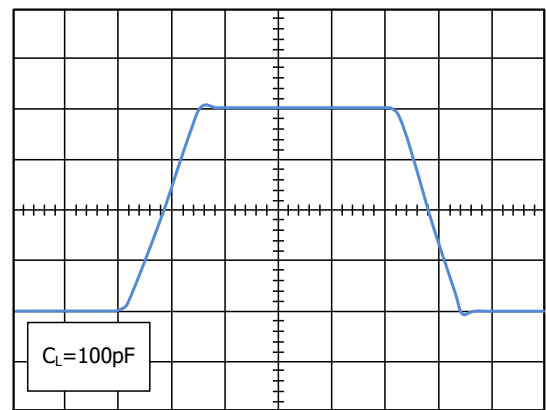

CH1: 1V/Div M: 1us/Div

Large-Signal Step Response

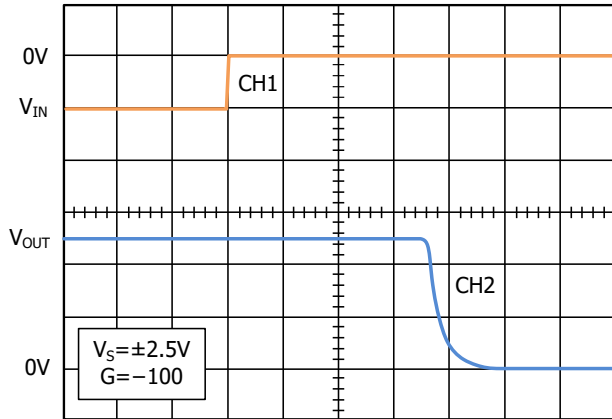

CH1: 200mV/Div CH2: 1V/Div M: 200ns/Div

Positive Overvoltage Recovery

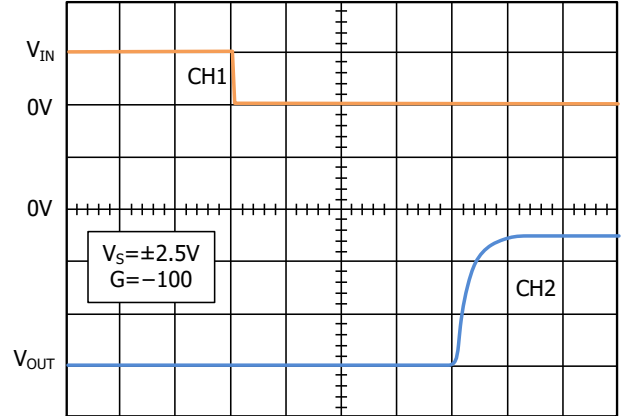

CH1: 200mV/Div CH2: 1V/Div M: 200ns/Div

Positive Overvoltage Recovery

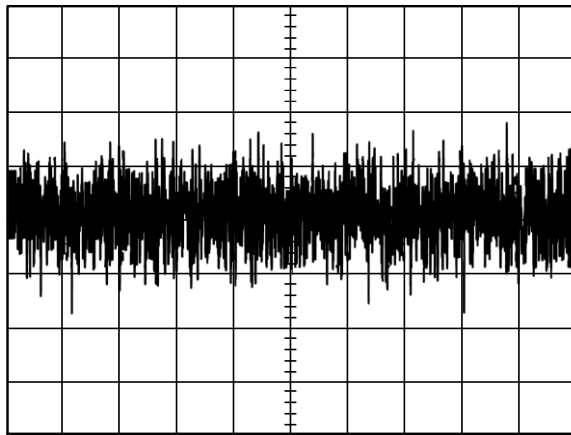

CH1: 200nV/Div M: 10s/Div

0.01Hz To 10Hz Noise at $V_S = 5V$

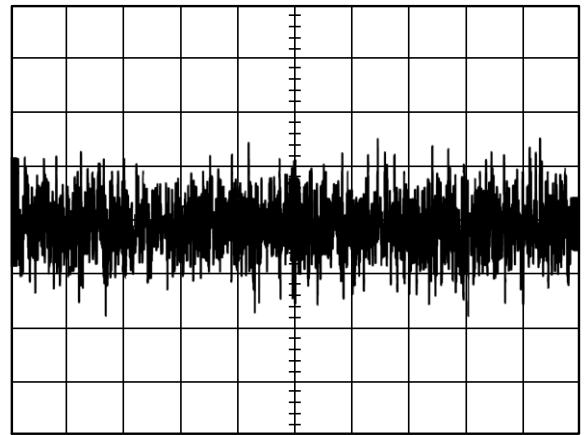

CH1: 400nV/Div M: 10s/Div

0.01Hz to 10Hz Noise at $V_S = 2.7V$

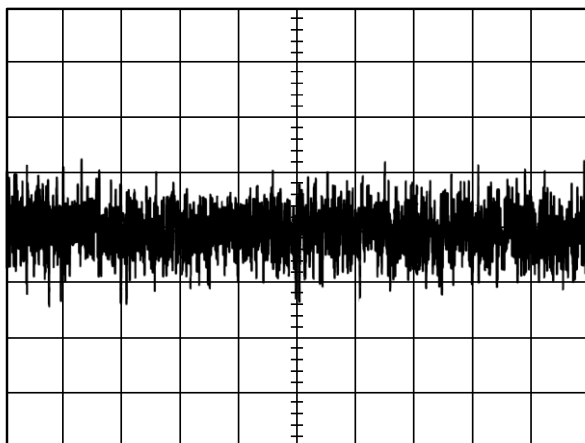

CH1: 100nV/Div M: 10s/Div

0.01Hz to 10Hz Noise at $V_S = 5V$

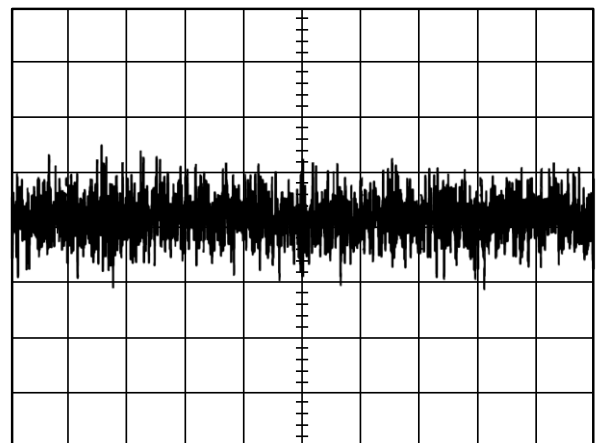

CH1: 200nV/Div M: 10s/Div

0.01Hz to 10Hz Noise at $V_S = 2.7V$



APPLICATION INFORMATION

The robust design of the AT855x family provides ease-of-use to the circuit designer due to the unity-gain stability, integrated RFI/EMI rejection filter, no phase reversal in overdrive conditions, and high electrostatic discharge (ESD) protection. They use auto zeroing techniques to provide low offset voltage and very low drift over time and temperature. Good layout practice mandates use of a 0.1µF capacitor placed closely across the supply pins. For lowest offset voltage and precision performance, circuit layout and mechanical conditions should be optimized. Avoid temperature gradients that create thermoelectric effects in thermocouple junctions formed from connecting dissimilar conductors. These thermally-generated potentials can be made to cancel by assuring that they are equal on both input terminals.

- " Use low thermoelectric-coefficient connections (avoid dissimilar metals).
- " Thermally isolate components from power supplies or other heat-sources.
- " Shield op amp and input circuitry from air currents, such as cooling fans.

Following these guidelines will reduce the likelihood of junctions being at different temperatures, which can cause thermoelectric voltages of 0.1µV/°C or higher, depending on materials used.

OPERATING VOLTAGE

The AT8551/AT8552 operational amplifier family operate over a power supply range of +2.7V to +5.5V (±1.35V to ±2.75V). Supply voltages higher than 7V (absolute maximum) can permanently damage the amplifier. In addition, many specifications apply from -40°C to 125°C. Power supply pins must be bypassed with 0.1µF ceramic capacitors. Parameters that vary over supply voltage or temperature are shown in the Typical Characteristics section of this datasheet.

MAXIMIZING PERFORMANCE THROUGH PROPER LAYOUT

For best operational performance of the device, use good printed circuit board (PCB) layout practices, including: Noise can propagate into analog circuitry through the power pins of the circuit as a whole and the operational amplifier. Bypass capacitors are used to reduce the coupled noise by providing low-impedance power sources local to the analog circuitry. Connect low-ESR, 0.1µF ceramic bypass capacitors between each supply pin and ground, placed as close to the device as possible. A single bypass capacitor from V+ to ground is applicable for single supply applications. Place the external components as close to the device as possible. Place the external components as close to the device as possible. Keep the length of input traces as short as possible. Always remember that the input traces are the most sensitive part of the circuit. Consider a driven, low impedance guard ring around the critical traces.

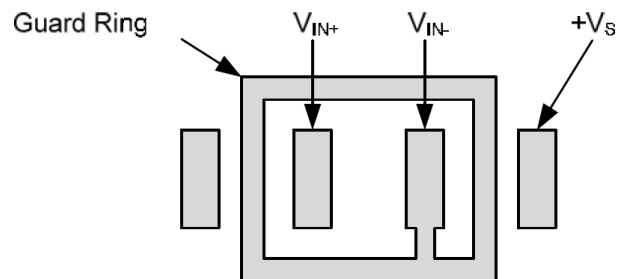
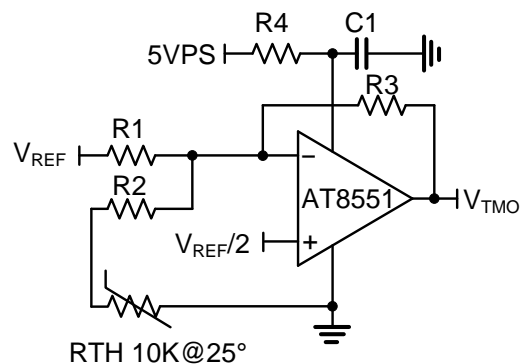

Figure 2. The Layout of Guard Ring

TYPICAL APPLICATION



R1, R2, R3 are TEC temperature control parameters, see Figure 4. Required temperature parameters can



be achieved through adjusting R1, R2 and R3, thus TEC controller can detect the temperature range that users require.

In different temperature ranges, R1, R2 and R3 have different corresponding resistances. R1, R2 and R3 can be determined by:

$$R1 = R_{MID} + \frac{R_{MID}(R_{LOW} + R_{HIGH}) - 2 * R_{LOW} * R_{HIGH}}{R_{LOW} + R_{HIGH} - 2 * R_{MID}}$$

$$R2 = R1 - R_{MID}$$

$$R3 = \frac{R1(R1 + R_{LOW} - R_{MID})}{R_{LOW} - R_{MID}}$$

EA

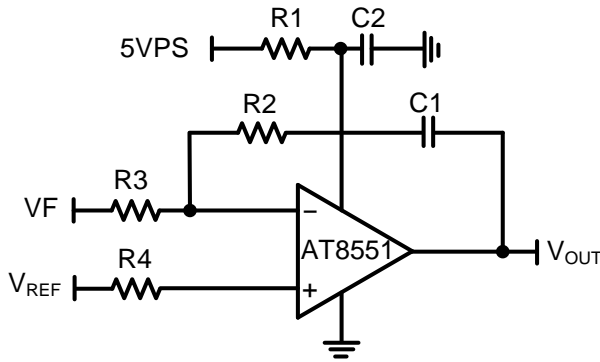

Positive Coefficient

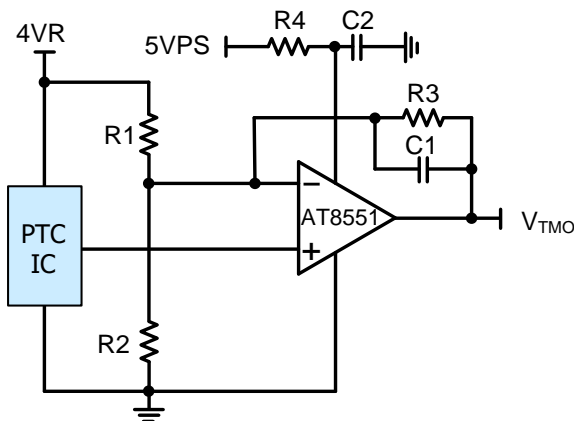

$$V_{TMO}(T_L) = 0.1V, V_{TMO}(T_U) = 3.9V$$

$$G = \frac{\Delta V_{TMO}}{\Delta V_{PTCIC}} = \frac{V_{TMO}(T_U) - V_{TMO}(T_L)}{V_{PTCIC}(T_U) - V_{PTCIC}(T_L)}$$

$$G = \frac{R3}{R1/R2} + 1$$

$$V_{PTCIC}(T_M) = \frac{V_{PTCIC}(T_U) + V_{PTCIC}(T_L)}{2}$$

$$V_{PTCIC} = V_{PTCIC}(T_M), V_{TMO} = \frac{3.9V + 0.1V}{2} = 2V$$

$$\frac{V_{PTCIC}(T_M)}{R2} = \frac{2V - V_{PTCIC}(T_M)}{R3} + \frac{4V - V_{PTCIC}(T_M)}{R1}$$

$$R3 = 20k\Omega$$

$$R2 = \frac{R3}{[4V - V_{PTCIC}(T_M)] \times G - 2}$$

$$R1 = \frac{R3}{G - 1 - \frac{R3}{R2}} = \frac{R2 \times R3}{R2 \times (G - 1) - R3}$$

Negative Coefficient

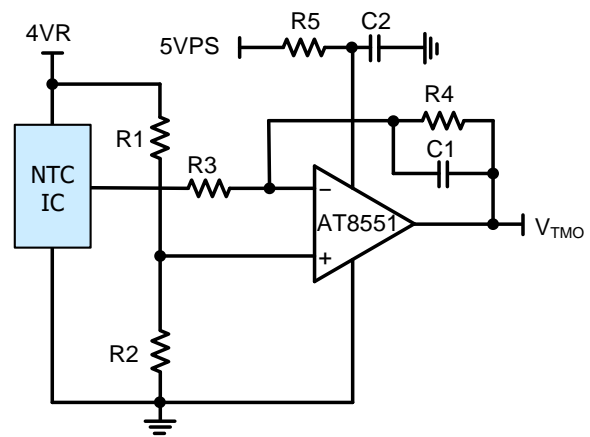

$$V_{TMO}(T_L) = 0.1V, V_{TMO}(T_U) = 3.9V$$

$$G = \frac{\Delta V_{TMO}}{\Delta V_{NTCIC}} = \frac{V_{TMO}(T_U) - V_{TMO}(T_L)}{V_{NTCIC}(T_U) - V_{NTCIC}(T_L)}$$

$$G = \frac{R4}{R3} \quad R3 = \frac{R4}{G}$$

$$R4 = 20k\Omega \sim 200k\Omega$$

$$V_{NTCIC}(T_M) = \frac{V_{NTCIC}(T_U) + V_{NTCIC}(T_L)}{2}$$

$$\frac{[2V - V_{NTCIC}(T_M)] \times R3}{R3 + R4} + V_{NTCIC}(T_M) = \frac{4V \times R2}{R1 + R2}$$

$$R2 = 10k$$

$$R1 = \frac{40 \times (1 + G)}{2 - V_{NTCIC}(T_M)} - 10$$



RTD

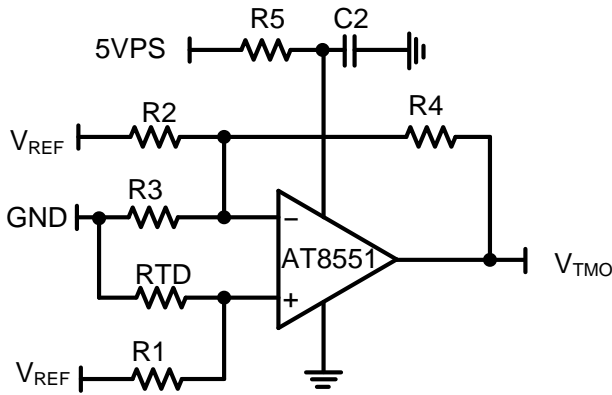

$$R_{TD} = R_0 \times (1 + 0.00385T)$$

e.g. $R_0 = 1k\Omega$

When $T = 10^\circ C$, $R_{TD}(10) = 1.0385k\Omega$

When $T = 40^\circ C$, $R_{TD}(40) = 1.154k\Omega$

Choose R_1

A. $P_{RTD} \leq 1mW$, $R_{TD} = 1000\Omega$

$$P_{RTD} = (I_{RTD})^2 \times 1000\Omega = 0.001W$$

$$I_{RTD} = 1mA = \frac{4VR}{R_1 + R_{TD}} = \frac{4}{R_1 + 1k} \implies R_1 = 3k\Omega$$

B. $P_{RTD} \leq 1mW$, $R_{TD} = 100\Omega$

$$P_{RTD} = (I_{RTD})^2 \times 100\Omega = 0.001W \implies$$

$$I_{RTD} = 3.16mA = \frac{4VR}{R_1 + R_{TD}} = \frac{4}{R_1 + 0.1k}$$

$R_1 = 1.15k\Omega$

$$V_{TMO} = \frac{4 \times R_{TD}}{R_1 + R_{TD}} \times \left[1 + \frac{R_4 \times (R_2 + R_3)}{R_2 \times R_3} \right] - \frac{4 \times R_4}{R_2}$$

I. When $T = 10^\circ C$, $R_1 = 3k\Omega$, $R_{TD}(T_L) = 1.0385k\Omega$,

$$0.93 = \frac{R_4 \times (2.97R_3 - 1.03R_2)}{R_2 \times R_3}$$

When $T = 40^\circ C$, $R_1 = 3k\Omega$, $R_{TD}(T_U) = 1.154k\Omega$,

$$2.79 = \frac{R_4 \times (1.11R_2 - 2.89R_3)}{R_2 \times R_3}$$

II. When $T = 10^\circ C$, $R_1 = 1.15k\Omega$, $R_{TD}(T_L) = 1.0385k\Omega$,

$$1.8 = \frac{R_4 \times (2.1R_3 - 1.9R_2)}{R_2 \times R_3}$$

When $T = 40^\circ C$, $R_1 = 1.15k\Omega$, $R_{TD}(T_U) = 1.154k\Omega$,

$$1.9 = \frac{2 \times R_4 \times (R_2 - R_3)}{R_2 \times R_3}$$

To achieve the required V_{TMO} outputs at the three different setting point temperatures in the Temperature Network, use the equation:

When $T = \text{LOW}$, $RTD = RTD_L$, $TMO = 0.1V$, $V_1 = V_{1L}$

When $T = \text{HIGH}$, $RTD = RTD_H$, $TMO = 4.0V$, $V_1 = V_{1H}$

$$\Delta TMO = 4V - 0.1V = 3.9V$$

$$\Delta V_1 = V_{1H} - V_{1L}$$

$$G = \frac{\Delta TMO}{\Delta V_1} = 1 + \frac{R_4 \times (R_2 + R_3)}{R_2 \times R_3}$$

$$RTD = R_0 \times (1 + 0.00385T)$$

e.g. $R_0 = 1k\Omega$

$$V_1 = 4.096V \times \frac{RTD}{R_1 + RTD}$$

$$V_{1L} = 0.5V$$

$$R_1 = RTD_L \times \frac{4.096V}{V_{1L}} - RTD_L$$

$$R_2 = R_1, R_3 = RTD_L$$

$$R_4 = (G - 1) \times \frac{R_2 \times R_3}{R_2 + R_3}$$

For example, setting the high set-point temperature at $60^\circ C$ and the low set-point temperature at $0^\circ C$. Use $RTD = R_0 \times (1 + 0.00385T)$, (e.g. $R_0 = 1k\Omega$).

$$RTD_L = RTD(10^\circ C) = 1.0k\Omega$$

$$RTD_H = RTD(60^\circ C) = 1.231k\Omega$$

$$R_1 = 7.192k\Omega, R_2 = R_1 = 7.192k\Omega$$

$$R_3 = RTD_L = 1.0k\Omega, R_4 = 32.308k\Omega$$



OUTLINE DIMENSIONS

MSOP-8

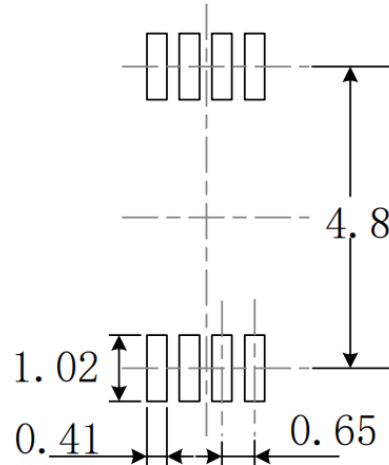
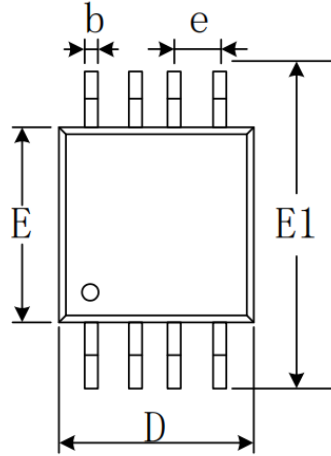

RECOMMENDED LAND PATTERN (Unit: mm)

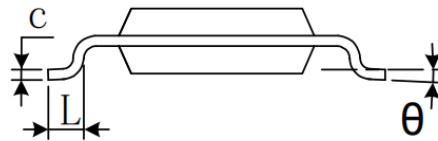
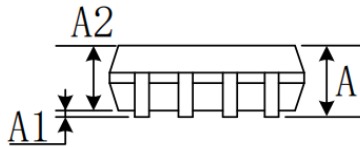

Symbol	Dimensions In Millimeters		Dimensions In Inches	
	Min.	Max.	Min.	Max.
A	0.820	1.100	0.032	0.043
A1	0.020	0.150	0.001	0.006
A2	0.750	0.950	0.030	0.037
b	0.250	0.380	0.010	0.015
c	0.090	0.230	0.004	0.009
D	2.900	3.100	0.114	0.122
e	0.650(BSC)		0.026(BSC)	
E	2.900	3.100	0.114	0.122
E1	4.750	5.050	0.187	0.199
L	0.400	0.800	0.016	0.031
θ	0°	6°	0°	6°



SOT23-5

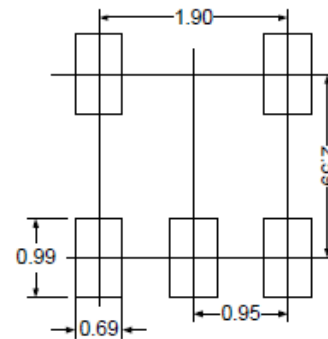
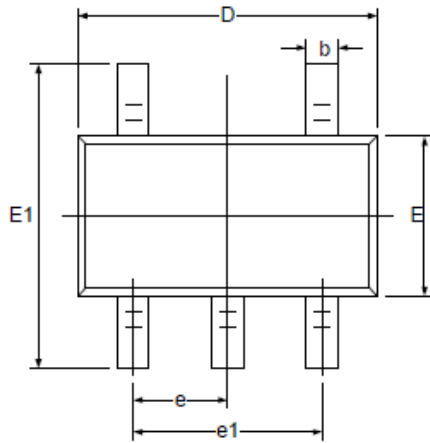

RECOMMENDED LAND PATTERN (Unit: mm)

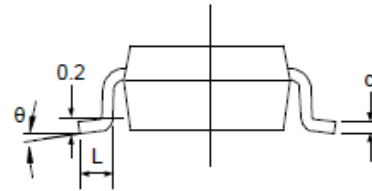
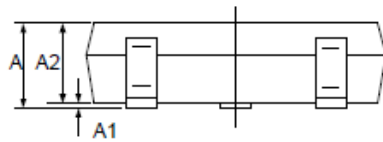

Symbol	Dimensions In Millimeters		Dimensions In Inches	
	Min.	Max.	Min.	Max.
A	1.050	1.250	0.041	0.049
A1	0.000	0.100	0.000	0.004
A2	1.050	1.150	0.041	0.045
b	0.300	0.500	0.012	0.020
c	0.100	0.200	0.004	0.008
D	2.820	3.020	0.111	0.119
E	1.500	1.700	0.059	0.067
E1	2.650	2.950	0.104	0.116
e	0.950(BSC)		0.037(BSC)	
e1	1.800	2.000	0.071	0.079
L	0.300	0.600	0.012	0.024
θ	0°	8°	0°	8°

SOIC-8

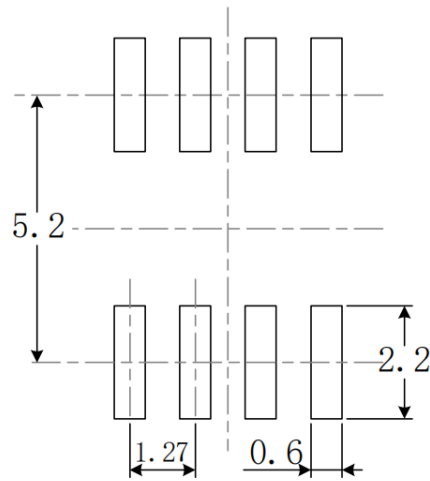
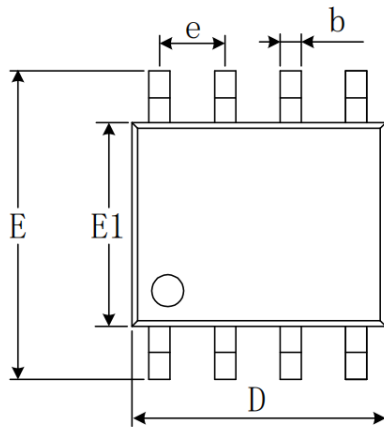

RECOMMENDED LAND PATTERN (Unit: mm)

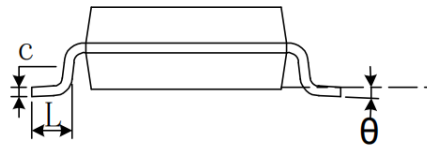
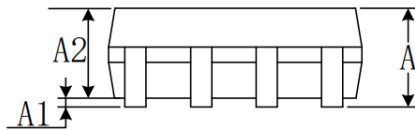





Symbol	Dimensions In Millimeters		Dimensions In Inches	
	Min.	Max.	Min.	Max.
A	1.350	1.750	0.063	0.069
A1	0.100	0.250	0.004	0.010
A2	1.350	1.550	0.053	0.061
b	0.330	0.510	0.013	0.020
c	0.170	0.250	0.007	0.010
D	4.800	5.000	0.189	0.197
e	1.270(BSC)		0.050(BSC)	
E	5.800	6.200	0.228	0.244
E1	3.800	4.000	0.150	0.157
L	0.400	1.270	0.016	0.050
θ	0°	8°	0°	8°



ORDERING INFORMATION

Table 4. Ordering Information

Part Number	Buy Now
AT8551	 *  *

*: both  and  are our online store icons. Our products can be ordered from either one of them with the same pricing and delivery time.

NOTICE

- ATI warrants performance of its products for one year to the specifications applicable at the time of sale, except for those being damaged by excessive abuse. Products found not meeting the specifications within one year from the date of sale can be exchanged free of charge.
- ATI reserves the right to make changes to its products or to discontinue any product or service without notice, and advise customers to obtain the latest version of relevant information to verify, before placing orders, that the information being relied on is current and complete.
- All products are sold subject to the terms and conditions of sale supplied at the time of order acknowledgment, including those pertaining to warranty, patent infringement, and limitation of liability. Testing and other quality control techniques are utilized to the extent ATI deems necessary to support this warranty. Specific testing of all parameters of each device is not necessarily performed, except those mandated by government requirements.
- Customers are responsible for their applications using ATI products. In order to minimize risks associated with the customers' applications, adequate design and operating safeguards must be provided by the customers to minimize inherent or procedural hazards. ATI assumes no liability for applications assistance or customer product design.
- ATI does not warrant or represent that any license, either express or implied, is granted under any patent right, copyright, mask work right, or other intellectual property right of ATI covering or relating to any combination, machine, or process in which such products or services might be or are used. ATI's publication of information regarding any third party's products or services does not constitute ATI's approval, warranty or endorsement thereof.
- IP (Intellectual Property) Ownership: ATI retains the ownership of full rights for special technologies and/or techniques embedded in its products, the designs for mechanics, optics, plus all modifications, improvements, and inventions made by ATI for its products and/or projects.